



MOTORIZED TROLLEYS

HOISTS



Accolift® Motorized Trolleys are rugged in design and built to be flexible right out of the box. Each trolley is adjustable for a beam flange range of 83mm to 305mm with no additional materials required. Side guide rollers are included to promote smooth trolley motion and to minimize wheel and beam flange wear.

Wheels are dual tread design for operation on tapered or flat flange beams. Trolleys include drop down lugs and rubber bumpers as standard equipment. Motor includes class F insulation and a disc type motor brake. Motor is rated for 30-minute duty and includes standard thermal protection. Three phase trolleys include a VFD control, 2-button pendant, control transformer and a 30' power cord. Single phase trolleys include a single speed contactor control, 2-button pendant and a 30' power cord.

Construction Features:

Motor: 30-min duty motor with class F insulation, thermal protection and motor brake (single phase motors are rated 20-min).

Three Phase Control: VFD control programmed for two speed operation.

Single Phase Control: Contactor control provided for single speed operation.

Side Frame: Side plates are rugged rolled steel.

Wheels: Dual tread design for operation on tapered or flat flange beams.

Bearings: Shielded, lifetime lubricated, single row ball bearings.

Suspension Lug: Pivot mounted suspension lug provides equally distributed load to all wheels.

Cap. (Tonnes)	Model Number	Trolley Speed (mpm)	Push Button Cord Length (m)	Power Cord Length (m)	Motor				Flange Width Adjustability (mm)	Wheel Diameter (mm)	Min. Beam Radius (mm)	Net Wt. (kg)
					HP	Amp. Draw						
						115V	208/230V	460V				
0.907	2130510-VFD	23/8	1.83	9.14	0.54	-	3.3/3.0	1.5	83 to 305	94	813	39.01
1.814	2130520-VFD	23/8	1.83	9.14	0.54	-	3.3/3.0	1.5	83 to 305	109	813	45.81
2.722	2130530-VFD	20/7	1.83	9.14	1	-	4.8/4.4	2.2	83 to 305	127	1016	74.84
4.536	2130550-VFD	20/7	1.83	9.14	1	-	4.8/4.4	2.2	83 to 305	140	1829	95.26

SINGLE PHASE TROLLEYS:

0.907	2330510	10.98	1.83	9.14	0.27	7.8	4.3/3.9	-	83 to 305	94	813	39.01
1.814	2330520	10.98	1.83	9.14	0.27	7.8	4.3/3.9	-	83 to 305	109	813	45.81

Figure A

Figure B

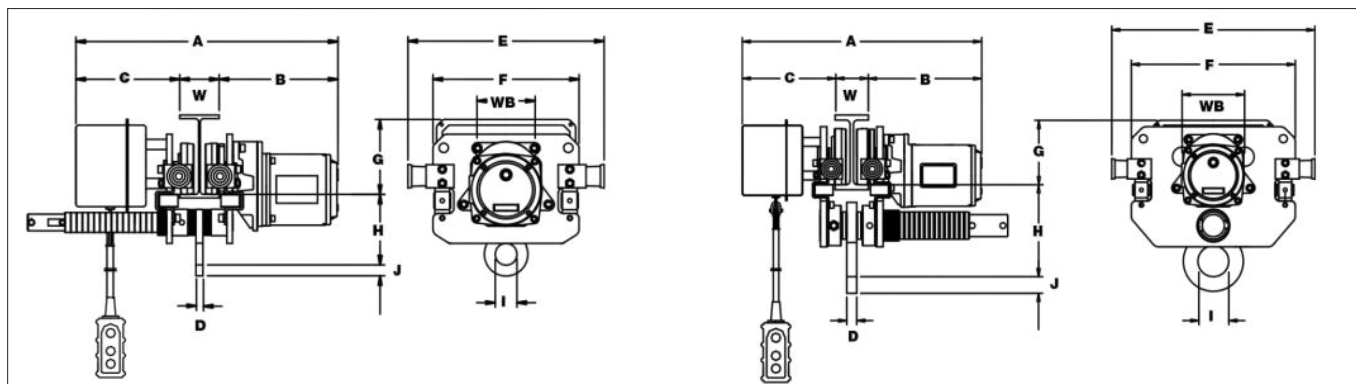

Model Number	A W = Beam Width	Dimensions (mm)										Figure
		B	C	D	E	F	G	H	I Diameter	J	WB	
2130510-VFD	475 + W	254	221	13	406	300	165	132	46	20	112	A
2130520-VFD	480 + W	257	224	15	424	315	163	152	46	23	124	A
2130530-VFD	503 + W	277	226	20	457	361	157	183	66	33	140	B
2130550-VFD	518 + W	284	234	25	508	409	160	229	76	36	155	B
2330510	475 + W	254	221	13	406	300	165	132	46	20	112	A
2330520	480 + W	257	224	15	424	315	163	152	46	23	124	A



HOOK DIMENSIONS

HAND CHAIN HOISTS

Capacity (Tonnes)	Dimensions (mm)				
	A	B	C	D	E
0.454	16	73	20	36	27
0.907	20	86	24	40	28
1.814	24	113	30	50	35
2.722	28	133	42	54	41
4.536	36	152	46	61	44
6.804	42	185	66	71	43
9.072	62	236	90	80	52
13.608	65	270	90	110	60
18.144	79	323	118	120	85

LEVER HOISTS

Capacity (Tonnes)	Dimensions (mm)				
	A	B	C	D	E
0.680	15	74	19	36	23
1.361	22	103	28	43	28
1.814	24	113	31	47	28
2.722	32	126	35	53	34
5.443	37	152	45	62	46
8.165	54	236	84	90	56

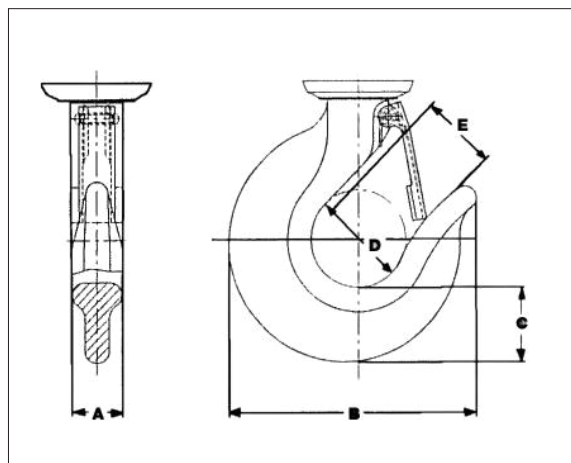

OPTIONS FOR HAND CHAIN HOISTS

Bronze wheels, nickel plated trolley and hoist body, nickel plated hand and load chain, bronze coated hook and load block.



Bronze wheels, bronze load hook and stainless steel load chain.



Stainless steel load chain, bottom block and hook.



Chain container.





HOISTS

PLAIN TROLLEYS



Accolift® Plain Trolleys are light and easy to adapt to a wide range of beams. The trolley wheels include lifetime lubricated ball bearings for maintenance free operation. A perfect match to make the Accolift electric or hand chain hoist and its load horizontally mobile.

Construction Features:

Side Frame: Side plates are rugged rolled steel

Wheels: Crown tread allows operation on tapered or flat flange beams

Bearings: Shielded, lifetime lubricated, single row ball bearings.

Suspension Lug: Pivot mounted suspension shaft designed to equally distribute the load to all wheels.

Options: Optional equipment available for this product includes bronze wheels and nickel plated body. Please contact the factory for more information.

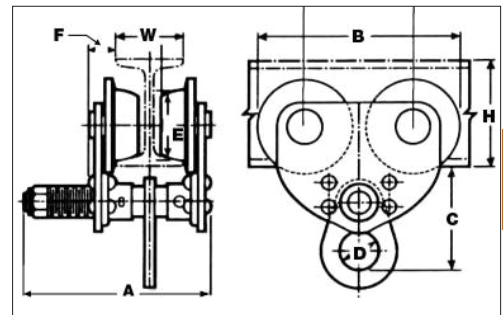

3

Model Number	Capacity (Tonnes)	W Beam Width Min. - Max. (mm)	Dimensions (mm)							Min. Beam Size H	Min. Beam Radius (mm)	Net Weight (kg)
			A	B	C	D	E	F	G			
1650010	0.454	76 to 127	206	175	130	46	56	28	89	102	610	6.35
1650020	0.907	76 to 127	206	231	130	46	81	28	122	127	762	9.98
1650030	1.814	76 to 152	236	269	155	61	99	36	142	152	914	18.60
1650040	2.722	76 to 152	251	312	191	66	114	48	163	178	914	28.58
1650050	4.536	127 to 178	282	353	231	76	124	53	183	254	1219	44.00

GEARED TROLLEYS



Accolift® Geared Trolleys are light and easy to adapt to a wide range of beams. The trolley wheels include lifetime lubricated ball bearings for maintenance free operation. A perfect match to make the Accolift electric or hand chain hoist and its load horizontally mobile for short distances and accurate load positioning.

Construction Features:

Side Frame: Side plates are rugged rolled steel

Wheels: Crown tread allows operation on tapered or flat flange beams

Bearings: Shielded, lifetime lubricated, single row ball bearings.

Hand Chain: Electric welded, close link galvanized coil chain, accurately and uniformly sized to seat properly in handwheel pockets.

Chain Guide: Steel chain guide.

Suspension Lug: Pivot mounted suspension shaft designed to equally distribute the load to all wheels.

Options: Optional equipment available for this product includes bronze wheels, stainless steel hand chain and nickel plated body. Please contact the factory for more information.

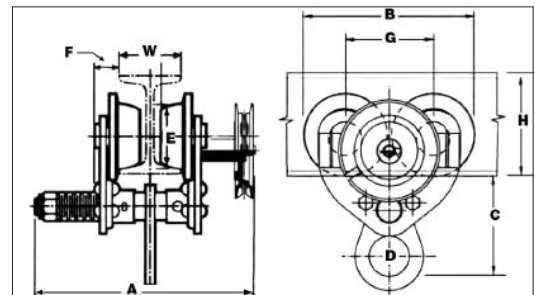

Model Number	Capacity (Tonnes)	W Beam Width Min. - Max. (mm)	Hand Chain Drop (m)	Dimensions (mm)							Min. Beam Size H	Min. Beam Radius (mm)	Net Weight (kg)
				A	B	C	D	E	F	G			
1650110	0.454	76 to 127	5.5	274	231	130	46	81	28	122	127	762	15.88
1650120	0.907	76 to 127	5.5	274	231	130	46	81	28	122	127	762	15.88
1650130	1.814	76 to 152	5.5	305	269	155	61	99	36	142	152	914	25.86
1650140	2.722	76 to 152	5.5	330	312	191	66	114	48	163	178	914	35.83
1650150	4.536	127 to 178	5.5	381	353	231	76	124	53	183	254	1219	51.71
1650160	9.072	127 to 191	5.5	432	353	279	81	124	53	183	254	1219	102.97